



(12) UK Patent (19) GB (11) 2 289 783 (13) B

(54) Title of Invention

A security system

(51) INT CL⁵; G07F 7/08, G06K 5/00, H04M 1/66, H04Q 7/00

(21) Application No
9413204.0

(22) Date of filing
30.06.1994

(30) Priority Data

(31) **94105095**

(32) **19.05.1994**

(33) **CN**

(43) Application published
29.11.1995

(45) Patent published
13.08.1997

(72) Inventor(s)
Kam-Fu Wong

(73) Proprietor(s)
**Kam-Fu Wong
No.1-3, Keng Hau Road
Shatin
Hong Kong**

(74) Agent and/or
Address for Service
**Forrester Ketley & Co
Forrester House
52 Bounds Green Road
London
N11 2EY
United Kingdom**

(52) Domestic classification
(Edition O)
**G4H HTG H1A H13D H14A
H4L LDSK LECX L1H10
U1S S2132 S2215 S2271**

(56) Documents cited
None

(58) Field of search

As for published application
2289783 A viz:
UK CL.(Edition M) **G4H HTG,
H4L LECX**
INT CL⁵ **G07F, H04M, H04Q**
updated as appropriate

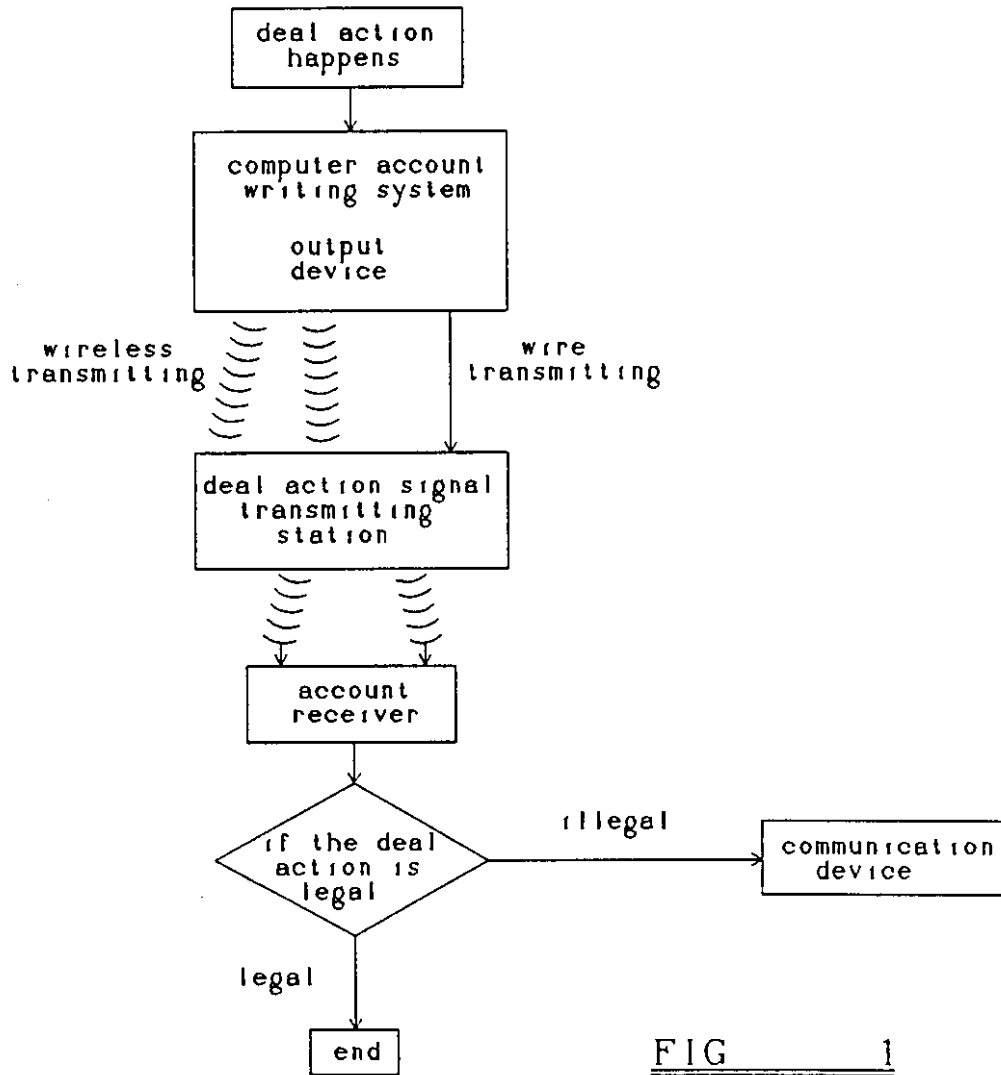

FIG 1

2 / 7

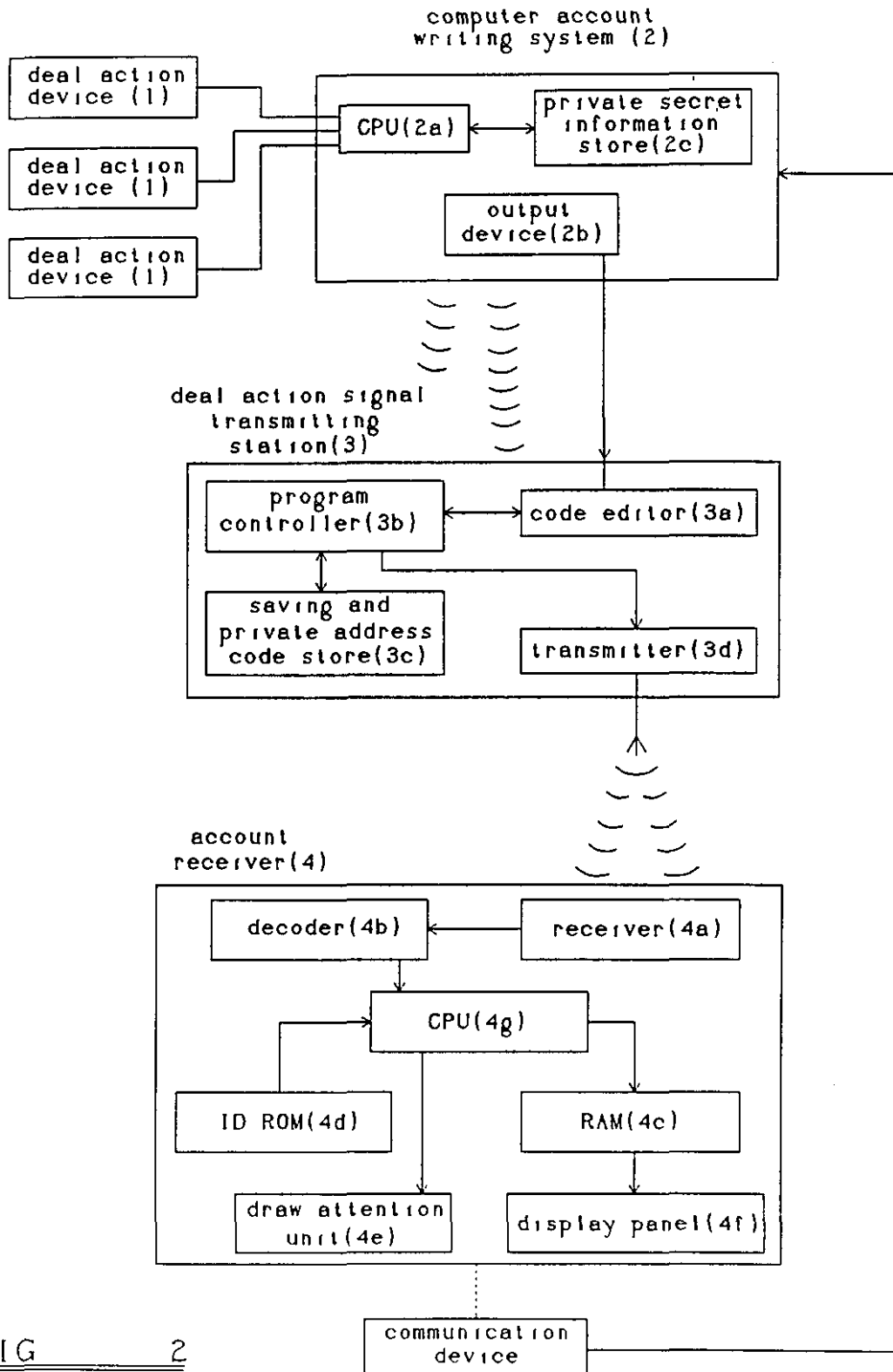
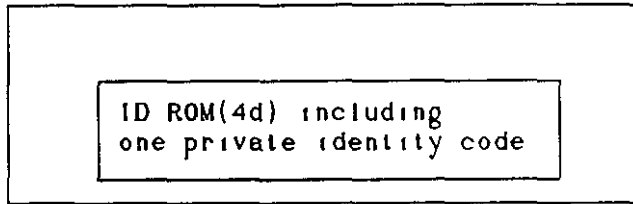

FIG 2

3 / 7

account receiver (4)



(3-1)

account receiver (4)

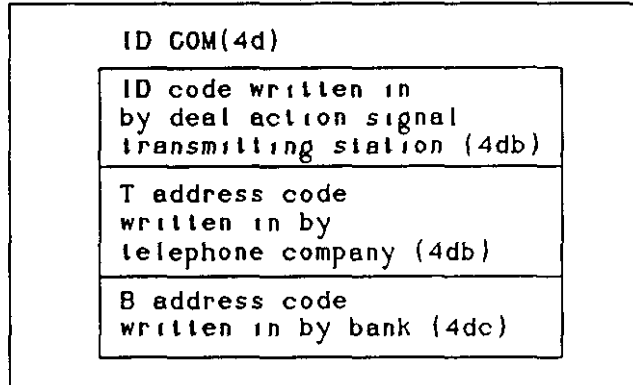

(3-2)

FIG 3

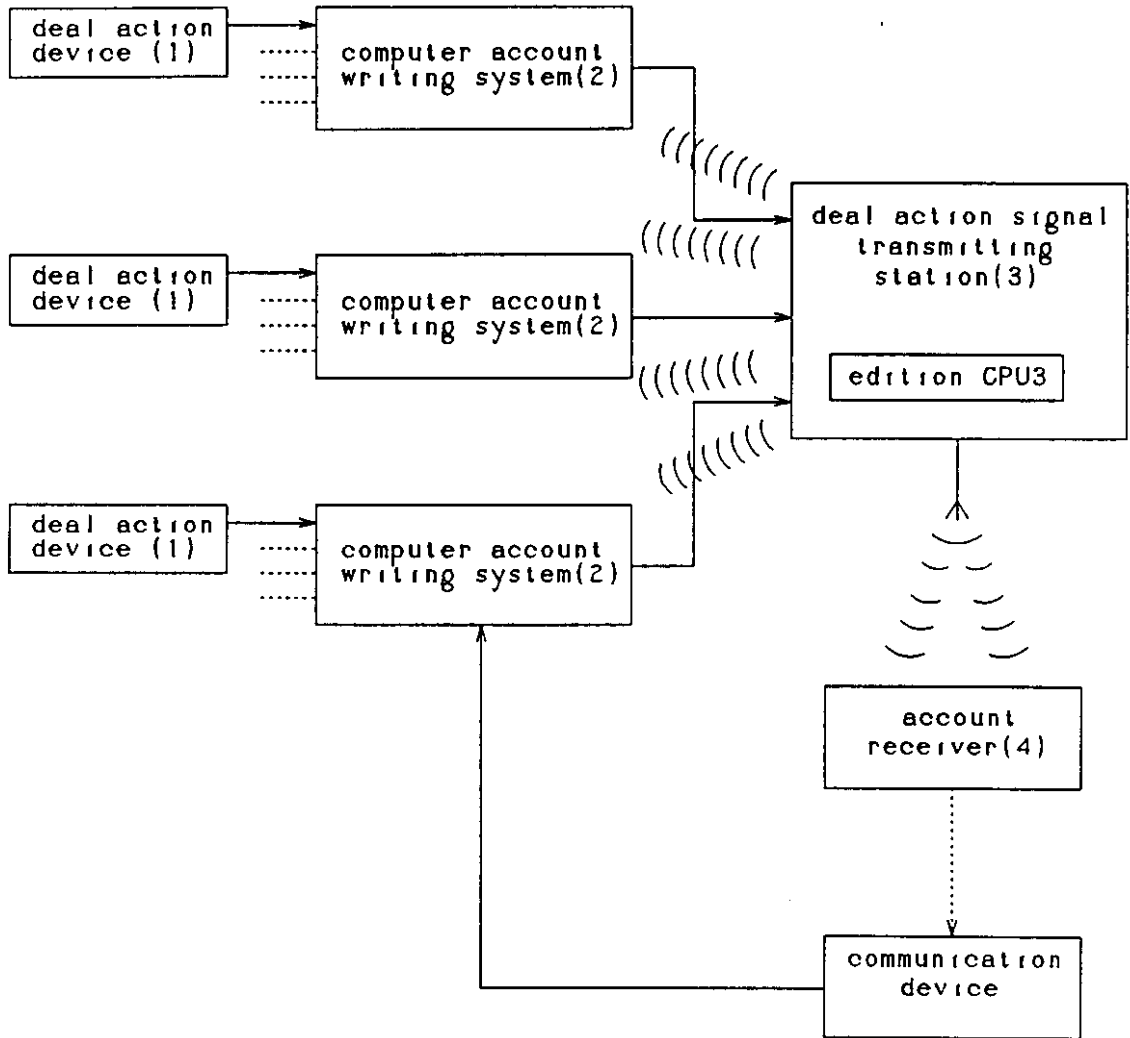

FIG 4

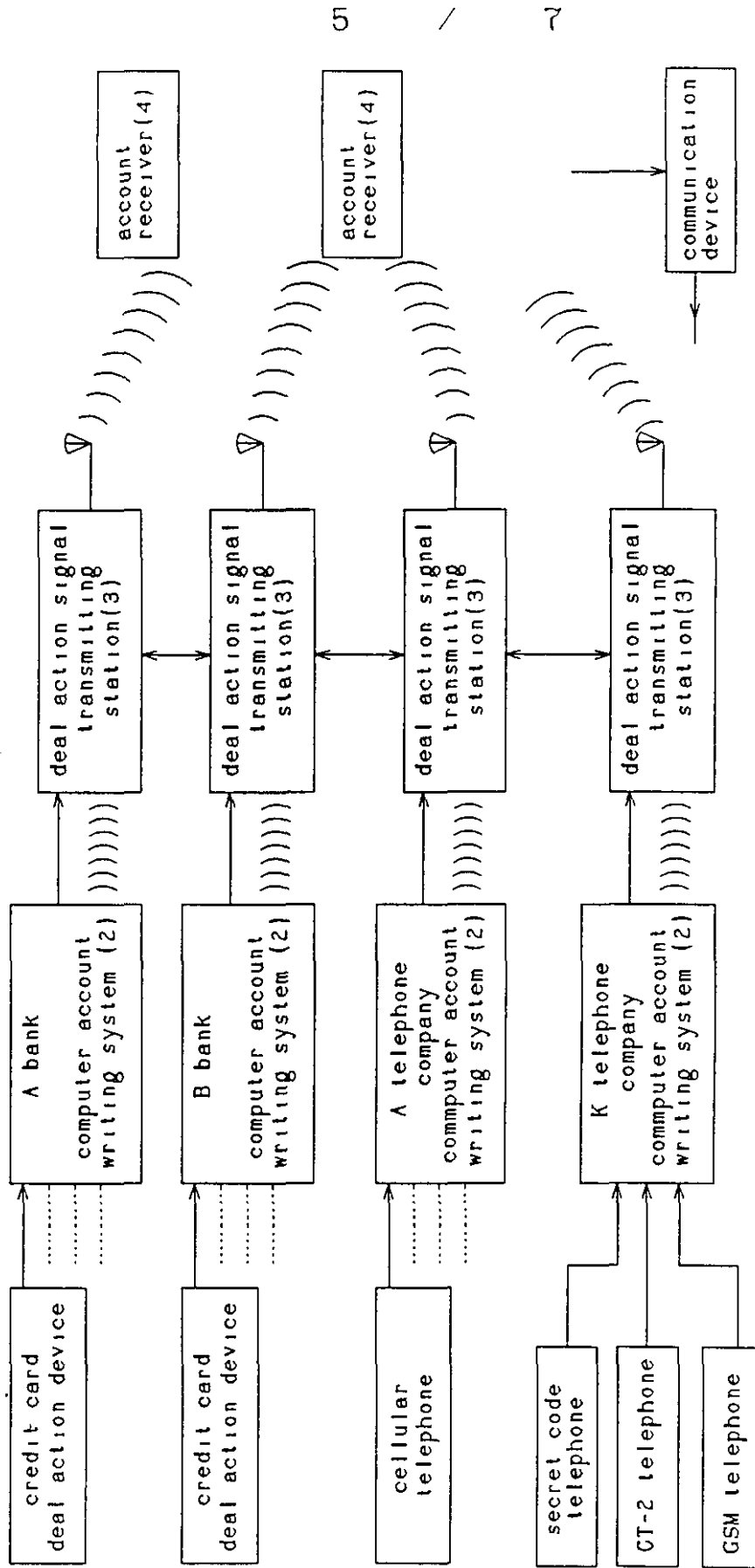

FIG 5

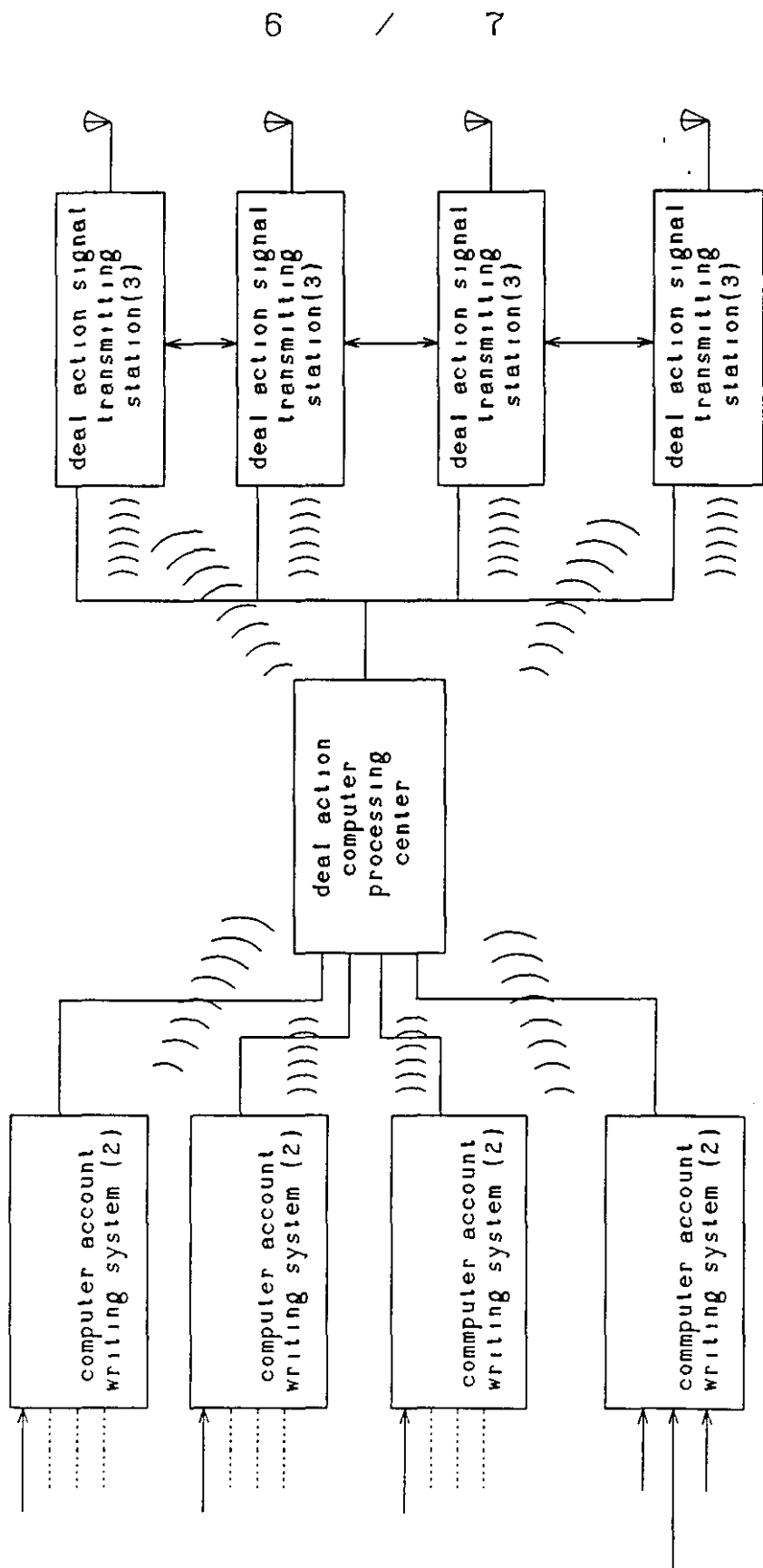

FIG 6

7 / 7

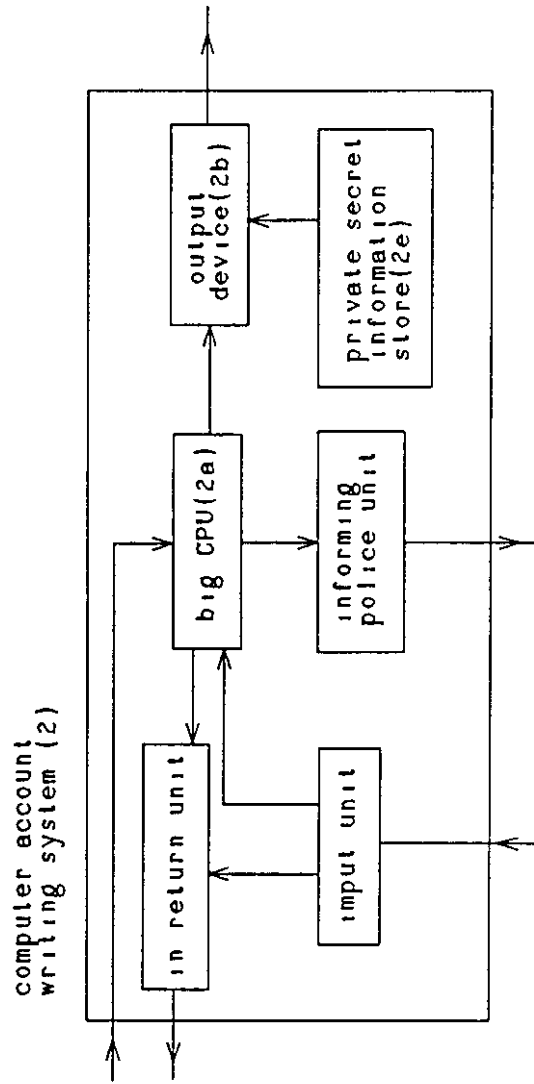

FIG 7

A security system

This invention relates to a security system and more particularly to a security system with which a bona fide owner can prevent others from using his stolen credit card and/or stolen mobile telephone.

In modern society, more and more transactions are by way of non-cash instant payments. For example, when people go shopping, use a private mobile telephone or cellular telephone to make a local call, make a long distance call or cross boarder roaming call, they then settle the bill monthly or quarterly. People also use various non-cash cards such as credit cards, debit cards, club cards, telephone cards and the like. All these transactions are either debited instantly from the owner's account or are added to a monthly/quarterly bill for the owner. The various transactions also include going to a restaurant, an hotel, paying for housing, buying air flight tickets or train tickets. After a period of time, the bills are settled by direct debit, cheque payment or the like.

People also use private secret codes, personal identification numbers (PINS) to authorise a transaction. A telephone, computer or a cash dispenser can be used to input a PIN to authorise a transaction.

When consumers use non-cash instant payment to pay bills and the like, they do not need to carry a lot of cash around with them. Thus, the consumer has less risk of losing cash, does not feel inconvenienced by carrying cash and is exposed to less contact with dirty bank notes which

people have touched. However, there are problems and risks associated with non-cash instant payments. Credit card transactions and cellular telephone calls are based on the use of modern electronic technology, computer technology and modem communication technology. These technologies are difficult to protect with known security methods. Criminals use advanced technology to steal consumers credit cards, their cellular telephones and to obtain information on the consumer's secret codes and personal identification numbers in order to make fake credit card transactions and cellular telephone calls. Increased use of non-cash instant payments is exacerbating these problems.

The following are examples of illegal non-cash instant payments.

When a consumer's mobile telephone is lost or stolen, the finder/thief can copy the internal characteristics of the mobile telephone such as ESN or MIN thereby making an illegal reproduction of the reproduction mobile telephone such that any further calls made on the mobile telephone are billed to the *bona fide* owner of the telephone.

When a consumer's cards, such as credit cards, goods cards etc are stolen by a thief, or the information contained on the credit card is stolen by a thief and an illegal card reproduced therefrom, retailers or banks may accept the stolen credit card or reproduced credit card resulting in losses to the consumers or banks. Records indicate that, at present, approximately 20 million credit cards per annum are registered as lost or stolen. The amount of money lost due to credit card fraud runs into several hundred million US\$. Until now there has been no really effective way of solving the above problems.

An object of the present invention is to solve or ameliorate the above mentioned problems.

Accordingly, the present invention provides a security system for preventing fraudulent transactions comprising: a deal action device for registering an attempted transaction; and communication means to alert a person authorised to make that transaction to the attempted transaction.

The present invention provides a method of protecting non-cash instant payment transactions. Even if the real owner of a credit card and/or mobile telephone is not aware that his card and/or mobile telephone has been stolen or is lost, he can immediately know when someone is using the stolen card and/or mobile telephone to make an unauthorised transaction. The real owner can then make a decision as to whether or not the transaction is legal or illegal. If the transaction is legal, then instant action can be taken to inform the bank/retailer/telephone company to stop the illegal transaction, to refuse payment of the goods, to stop the use of the credit card or to stop the use of the mobile telephone so that any losses to the real owner, the bank, the retailer are reduced or even eliminated. It is envisaged that the method according to the present invention will thereby reduce or eliminate this kind of commercial crime.

In order that the present invention may be more readily understood, embodiments thereof will now be described, by way of example, with reference to the accompanying drawings, in which:

Figure 1 is a flow chart of a method of using a security system embodying the present invention;

Figure 2 is a schematic block diagram of a security system embodying the present invention;

Figures 3-1 and 3-2 are diagrammatic representations of address codes stored within account receivers;

Figure 4 is schematic block diagram of another security system embodying the present invention;

Figure 5 is a schematic block diagram of a further security system embodying the present invention;

Figure 6 is a schematic block diagram of a deal action signal computer processing centre for use with a security system embodying the present invention; and

Figure 7 is a schematic block diagram of a police informing unit for use with a security system embodying of the present invention.

Figure 1 represents a flow chart indicating the steps according to one method of using a security system embodying the present invention. When a person uses a mobile telephone or a car telephone to make a call, or someone attempts to make a transaction using a credit card, then a non-cash instant payment transaction takes place. Such a transaction is termed herein a "deal action". The dialling of the mobile telephone alerts a computer account writing system of the telephone company operating the mobile telephone that the mobile telephone is being used and begins to calculate and record the time, the place, distance and charge for the telephone call. When someone uses a credit card to effect a transaction and the credit card is read by a credit card reading device at the point

of sale, then a corresponding computer account writing system in a bank or retailing outlet starts to operate to record the transaction on the card. At that time, the computer account writing system, for example, at a bank, creates a deal action signal. The computer account writing system evaluates from the information provided the private address code of the real owner of the credit card/telephone. An output device within the computer account writing system outputs a signal including the deal action signal to a deal action signal transmitting station by way of radio transmission, telephone network or other communication cable. The deal action transmitting station processes the received signals and then transmits such signals over a large area. The real owner of the credit card/mobile telephone carries an account receiver which receives the transmitted signal, including the deal action signal, thereby alerting the real owner that a deal action indicative of a transaction is being made by someone using the owner's credit card or telephone.

For example, the account receiver may possess a display device which can indicate the sign "B25" to indicate that the owner's credit card is being used in a transaction amounting to US\$25. Further examples might be the indication "STBJ" indicating that the owner's cellular telephone is being used to call Beijing. When the owner receives the signal via the account receiver, the owner can make an immediate decision as to whether or not the deal action is legally arranged by himself or is being performed illegally by others, for example, if the telephone being used to make the call is an illegal reproduction telephone or whether the credit card is a fake reproduction using stolen codes. Depending upon standing instructions, unless the computer account writing system receives orders to the contrary, for example, within two or three minutes, the

computer account writing system will authorise the deal action. If the real owner believes that the deal action is illegal, he can immediately use any form of communication device, such as a telephone, to inform the respective computer account writing system that the deal action is illegal. If this is the case, then the computer account writing system will send a pre-arranged signal back to the point of sale or bank where the deal action is taking place to tell the deal action device to refuse the deal action or stop of the deal action. For example, the signal on the screen of the credit card reading device at the point of sale may indicate that the card is refused, or the signal allowing the cellular telephone to operate is broken to close the call. In this way, the real owner, the bank, the telephone company and the retailers avoid or reduce any losses due to such illegal deal actions. Commercial crimes of this nature may thus be eliminated. The whole procedure may take around one or two minutes or perhaps even less.

Referring to Figure 2, a system is shown having: a plurality deal action devices 1; a plurality of corresponding computer account writing systems 2; one or more deal actions signal transmitting stations 3; a plurality of account receivers 4; and one or more communication devices. The deal action devices 1, as previously mentioned, can be various devices such as credit card reading devices, cellular telephones, cash dispensers or the like, all of which are non-cash instant payment devices. The deal action devices 1 generate deal action signals when a transaction is taking place and send the deal action signals to the computer account writing system 2. The computer account writing system 2 includes a central processing unit (CPU) 2a, an output device 2b and a private secret information store 2c. The CPU 2a is used to record the deal action information received in the deal

action signal from the deal action device 1. For example, if the computer account writing system is in a bank computer, the information will be the place of using the credit card, the time and date of the transaction, the value of the transaction, the card number or, if the CPU is in the computer in a telephone company, the information will be the number of the cellular telephone, where the telephone dials to and the telephone number dialled, time and date, the time spent on the call etc. The CPU 2a will refer to the private address code stored in the private secret information store 2c, process the signals inputted from the deal action device 1 and send the process signals including the deal action signals to the output device 2b. The output device 2b immediately outputs all the information signals to the deal action signal transmitting station 3 by way of wireless transmission, telephone network or suitable communication cables. The deal action signal transmission station 3 includes a code editor 3a, a program controller 3b, a saving and private address code store 3c and a transmitter 3b which takes the incoming information signals and checks to the private secret code of the real owner is the same as the private address code in the store 3c to encode the same in the coded editor 3a. The program controller 3b transfers the code signals to the transmitter 3d which immediately transmits the coded deal action information to a cover area within which the real owner is located such that the deal action information signals can be received by the real owner. The real owner must have an account receiver 4 for receiving the deal action information. The account receiver 4 comprises a receiver 4a, a decoder 4b, a central processing unit (CPU) 4g, a random access memory (RAM) 4c, an alert unit 4e, a display panel 4f and an identification read only memory (ROM) 4d.

The receiver 4a receives the encoded deal action information signals transmitted by the deal action signal transmitting station 3 and sends the same to the decoder 4b. The decoder 4b refers to the private address code of the real owner in the identification ROM 4d, and decodes the deal action information signals and sends the signals to the CPU 4g. The CPU 4g controls the program arrangements and starts the alert unit 4e and display panel 4f and RAM 4c. The alert unit 4e can comprise an audio unit, a vibration unit, a liquid crystal display unit or the like and is used to alert the real owner to the fact that a deal action concerning him is occurring. The display panel 4f shows the information concerning the deal action. The random access memory 4c is a memory to store the deal action information temporarily. When the real owner requires the deal action information, he can use the information stored in the RAM 4c. When the real owner does not need said information any longer, he can input instructions to clear the information stored in the memory 4c.

The real owner can judge from the display 4f whether or not the deal action is legal or illegal. If the deal action is arranged by the real owner himself, such as a company manager using a company credit card to pay a bill for inviting company guests for dinner together, the deal action is legal. The real owner of the credit card does not need to take any further action. The deal action will be authorised as previously described and may go ahead. If the symbols shown on the display 4f let the real owner know that the deal action is illegal, such as a deal action involving somebody using the owner's cellular telephone and the cellular telephone has just been lost, or if someone is using a fake credit card with stolen information relating to the owner to pay a bill, then the real owner may use any

communication device, such as a telephone to inform the corresponding computer account writing system 2 to refuse or stop the illegal deal action. The computer account writing system 2 will according to the order in which the real owner sends the instruction signals to refuse or stop the deal action to the deal action device 1. For example, when the deal action device 1 is a credit reading device 1, by instructing said device to refuse the payment, or by reverting back to the mobile telephone being used and interrupting the call. In this way, the losses of the real owner of the credit card and/or the mobile telephone can be reduced as may the losses of the bank concerned and the telephone company. In this way, commercial crimes involving illegal use of the non-cash instant payment transactions may be reduced or eliminated. Such a system will bring great benefits for society and the economy of a country.

Computer account writing system 2 may be the present computer account writing system used in banks or telephone companies with an additional output device 2b. The output device 2b is used for transferring the deal action information of the real owner to the deal action signal transmitting station 3. The deal action signal transmitting station 3 can be a widely used paging system or other form of transmitting station. The account receiver may be a pager, a portable pager, a table pager or a watch or clock with a CPU 4g, an immediate alert unit 4e and a display panel 4f to receive and display deal action information signals. Alternatively, the account receiver may be a mobile telephone, normal telephone or a computer or a specially designed electric or electronic device for receiving and displaying deal action information signals and for drawing the real owners attention thereto by way of the alert unit 4e.

Figure 3 shows two examples of account receivers 4 and the respective identification ROM 4d of the account receiver 4. The account receiver 4 includes a private identity address code written into the identification ROM 4d by the deal action signal transmitting station 3. The address code is similar to that given to each pager used such that each pager may be selectively identifiable by the paging station. By virtue of the address code, a message from the deal action signal transmitting station 3 will not be received by each and every account receiver 4 but only by the account receiver 4 associated with that person's account receiver 4. The address code may be a number having several digits, such as an eight digit number, a ten digit number etc. The person carrying the account receiver 4 does not need to know the private identity address code. The private identity address code may be written in advance into the ID ROM 4d by the account receiver manufacturer or can be written in by the deal action signal transmitting station 3 or by the user manually changing the address code and then informing the deal action signal transmitting station. Generally speaking there is at least one private address code in the ID ROM 4d of the account receiver 4 as shown in Figure 3-1. The account receiver 4 must be capable of receiving deal action signals, for example, in deal action signals of various credit cards, when the output device 2b of the bank computer account writing system transmits the deal action signals, a distinguished code identifying the correct owner of the credit card must be added. For example, the distinguishing code of a person is CB12450 and the deal action signal is B25. The display panel 4f of the account receiver 4 will show the symbols CB12450+B25.

The account receiver shown in Figure 3-2 may receive deal action signals from using a credit card. The

bank concerned which issues the credit cards may write into its bank computer system a B address code in the identification ROM 4d of the account receiver which can distinguish other credit cards. For every credit card, the bank writes a B address code for the real owner ie. the credit card owner in the ID ROM of the account receiver 4. In the same way, for every mobile telephone such as a cellular telephone, the telephone company uses the computer account writing system 2 to write in a T address code in the identification ROM 4d of the account receiver 4 for the real owner. Then, in the account receiver 4 there is at least an identification code written in by the deal action signal transmitting station, a B address code written in by the respective bank and a T address code written in by the respective telephone company.

Of course, all these codes may be written in by a pager menu feature if the account receiver comprises a pager. Thus, there are usually two to three address codes in the account receiver 4. Thus, when the deal action occurs, such as the example mentioned above, the display panel 4f of the account receiver 4 will only show B25 instead of CB12450+B25. Since the address code was already written in the account receiver 4, the symbol CB12450 can be saved and more deal action information symbols can be shown in the display panel 4f. More deal action information can thus be presented to the real owner. The display symbol BK can be used for a credit card deal action, the symbol ST for a cellular telephone deal action and the symbol KT for a secret code telephone deal action.

Figure 4 illustrates a similar embodiment to that shown in Figure 2 in which a plurality of deal action devices are each associated with a corresponding computer

12

account writing system, which plurality of computer account writing systems go through a single deal action signal transmitting station 3. Since the deal action signal transmitting station 3 is connected to a plurality of

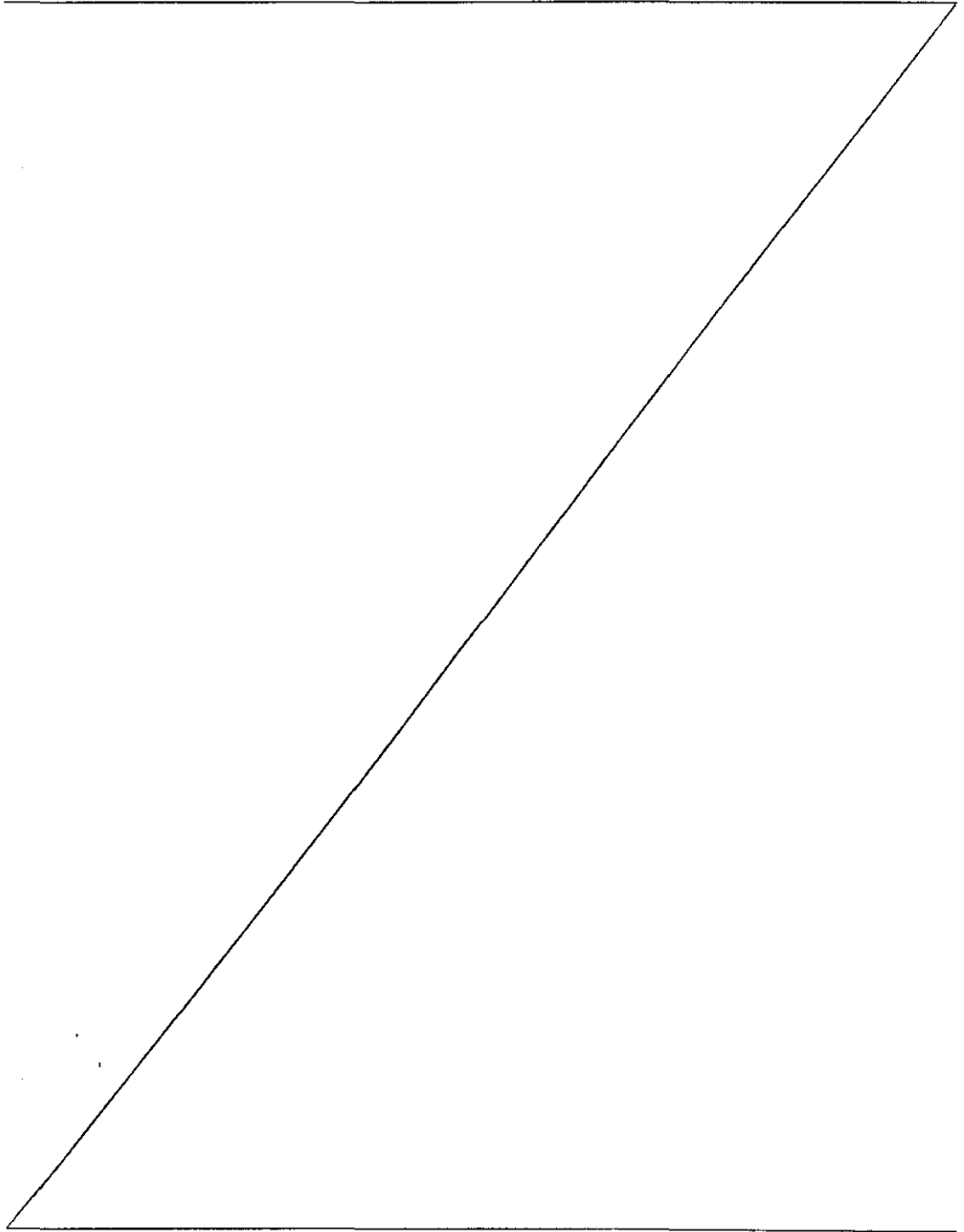

13

computer account writing systems 2, the code editor 3a can increase the working capacity and speed of the deal action information.

The whole process from the occurrence of the deal action to the display of the deal action information on the account receiver 4 may take just seconds.

Figure 5 shows another embodiment of the present invention in which many computer account writing systems go through a corresponding number of deal action signal transmitting stations 3 to transmit deal action information.

The deal action information signals can be transferred among the deal action signal transmitting stations such that the deal action information signals are transmitted through several areas, several regions in a country, or several countries and even throughout the world.

Figure 6 shows another embodiment of the present invention in which a plurality of computer account writing systems and a plurality of deal action signal transmitting stations 3 are linked by a single deal action signal computer processing centre 6 which processes a large number of deal action information signals coming from all the computer account writing systems 2 and which immediately transfers the signals to the correct deal action signal transmitting stations to transmit such information.

Figure 7 shows a still further embodiment of the present invention which includes a police informing unit 2f in the computer account writing systems. When a real owner has indicated that a deal action is illegal and the deal

4

action is to be refused or stopped, then before such instruction is sent to the deal action device, the police informing unit is activated and informs the police that an illegal deal action is taking place and where said deal action is taking place so that the police can take immediate action to seize the illegally acting people.

Of course, a more sophisticated account receiver 4 can be used which can display more information such as what kind of transaction is being conducted, which card is being used, the number of the credit card, how much money is going to be spent in the transaction, which kind of telephone is being used, be it mobile, car, cellular or secrete code telephone, the place and time of the telephone call, the number being dialled, and the place of using the credit card. All this information may be displayed by way of symbols, words and characters on a display device on the account receiver 4. Thus the real owner can take the necessary action to stop illegal deal action.

Accordingly, when non-cash instant payment transactions such as payments by credit card, dialling a mobile telephone etc. occur, the method and security system embodying the present invention provides the real owner of the credit card/mobile telephone with immediate knowledge that such a transaction is occurring so that the real owner can take the appropriate action.

It should be understood that when a non-cash instant payment transaction occurs, the corresponding computer account writing system shall be operating. The computer account writing system can be the bank's computer system, or some service company's computer system such as a cellular telephone service company's computer system. All the above computer systems are termed herein "computer

15

account writing systems". The computer account writing system shall output information signals which include that a deal action (non-cash instant payment transaction) is occurring and the private address code of the real owner recorded in the system to the deal action signal transmitting station by way of a communication method such as wireless communication, transmitting the information through a telephone line network or suitable communication cable. The deal action signal transmitting station immediately sends out the deal action information signals according to the ID code of the real owner in the station in the appropriate covering area. The real owner can rapidly receive the signals by an account receiver carried with him that a deal action concerning him is happening. According to the signals received, the real owner can make a judgement at once whether he needs to take action or not. If within a prearranged time such as two or three minutes, the real owner does not take such action, it is presumed that the real owner agrees to the deal action and the deal action is thereby authorised. Should the real owners think that the deal action is an illegal use of a stolen credit card or the like, he can use whatever communications means are necessary to inform the corresponding computer account writing system of the illegal use. A computer account writing system will send back signals to the location where the deal action is occurring such as back to the credit card reading device, to refuse payment or signals may be sent to the mobile telephone to break the telephone connection. Thus, the losses to the real owner and the concerned service company or bank will be reduced or eliminated. The commercial crimes of using credit cards fraudulently and or stolen cellular telephones will thus be prevented.

16

CLAIMS:

1. A security system for preventing fraudulent transactions comprising:

a deal action device for registering an attempted transaction; and

communication means to alert a person authorised to make that transaction of the attempted transaction.

2. A security system according to Claim 1, wherein further communication means are provided to allow the authorised person to authorise or prevent the attempted transaction.

3. A security system according to Claim 1 or 2, wherein a computer account writing system is provided, which computer account writing system is in communication with the deal action device for receiving details of the attempted transaction and is operable to communicate details of the attempted transaction to the authorised person.

4. A security system according to any preceding claim for immediately informing the real owner that a non-cash instant payment deal action concerning him is happening, comprising:

a deal action device; a computer account writing system; a deal action signal transmitting station; and an account receiver, the deal action device comprising a card reading device for reading a card when a deal action happens, the deal action device creating deal action information and transferring the deal action information to the corresponding computer account writing system, the computer account writing system processing the incoming deal action information signals from the deal action

A

device, comparing a private address code of the real owner with the code in a private secret information store, sending these information signals to the deal action signal transmitting station, the deal action signal transmitting station comprising a code editor, a program controller, a saving and private address code store and a transmitter, the code editor combining the private address code of the real owner in the saving and private address code store and encoding the received various deal action information signals, the program controller ordering the transmitter to transmit immediately the coded signals of the deal action information signals combined with the private address code; the account receiver including a receiver, a decoder RAM ID ROM draw attention unit, a display panel and a CPU; the receiver receiving the encoded/information signals related to the private address code transmitted from the deal action signal transmitting station, and sending to the decoder to decode, under the control of the CPU, to start the alert unit to provide an indication of information arriving, and on the display panel, displaying the deal action information with symbols, numbers, words or characters, and storing the deal action information in RAM for later use.

5. A security system according to Claim 4, wherein the computer account writing system is a credit card computer account writing system used in a bank with an additional output device or is a telephone account computer system used in a telephone company with an additional output device.

6. A security system according to Claim 4 or 5, wherein the deal action signal transmitting station is a paging station or paging system.

18

7. A security system according to Claim 4, 5 or 6, wherein the account receiver is a portable pager, a table pager, a watch, a mobile telephone, a general telephone computer or a special designed electric or electronic device to receive deal action information signals and display the deal action information and has an alert unit to alert the relevant real owner.

8. A security system according to Claim 4 or 7, wherein the ID ROM of the account receiver has at least a private address code-ID code written in by the deal action signal transmitting station and/or further address codes comprising a T address code, written in by a telephone company and/or a B address code, written in by a Bank computer account writing system.

9. A security system according to Claim 4, wherein the deal action signal transmitting station sends different display symbols for different deal actions, said display symbols comprising "BK" concerning a credit card deal action, ST concerning a cellular telephone deal action, KT concerning a secret code telephone deal action, numbers concerning the monetary value of the deal action, and symbols and numbers and words and characters concerning the place of the deal action and the called telephone number.

10. A security system according to Claim 4, wherein a plurality of computer account writing systems and deal action signal transmitting stations are provided which can be connected into a network, whereby the signal cover area transmitted by the deal action signal transmitting station can be spread as required.

11. A security system according to Claim 4 or 10, wherein a deal action signal computer processing centre is

P1

provided for increasing the number of deal action signals and enhancing the processing speed.

12. A method of utilising an electric or electronic communication system to immediately inform the real owner that a non-cash payment deal action concerning him is happening, comprising the following steps: during the time of a deal action transmitting information concerning the deal action to the real owner, allowing the real owner to make a decision as to whether or not the deal action is authorised and informing the deal action device of the real owner's decision.

13. A security system substantially as hereinbefore described with reference to and as shown in the accompanying drawings.

OA80-01
FG

OPTICS - PATENTS

07/11/97 10:56:58

PAGE: 1

RENEWAL DETAILS

PUBLICATION NUMBER GB2289783

PROPRIETOR(S)

Kam-Fu Wong, No.1-3, Keng Hau Road, Shatin, Hong Kong

DATE FILED 30.06.1994

DATE GRANTED 13.08.1997

DATE NEXT RENEWAL DUE 30.06.1998

DATE NOT IN FORCE

DATE OF LAST RENEWAL

YEAR OF LAST RENEWAL 00

STATUS PATENT IN FORCE

**** END OF REPORT ****

REGISTER ENTRY FOR GB2289783

Form 1 Application No GB9413204.0 filing date 30.06.1994

Priority claimed:

19.05.1994 in China - doc: 94105095

Title A SECURITY SYSTEM

Applicant/Proprietor

KAM-FU WONG, No.1-3, Keng Hau Road, Shatin, Hong Kong [ADP No. 01397009002]

Inventor

KAM-FU WONG, No.1-3, Keng Hau Road, Shatin, Hong Kong [ADP No. 01397009002]

Classified to

G4H H4L U1S

G07F G06K H04M H04Q

Address for Service

FORRESTER KETLEY & CO, Forrester House, 52 Bounds Green Road, LONDON, N11
2EY, United Kingdom [ADP No. 00000133001]

Publication No GB2289783 dated 29.11.1995

Examination requested 19.03.1996

Grant of Patent (Notification under Section 18(4)) 15.07.1997

Publication of notice in the Official Journal (Patents) (Section 25(1))
13.08.1997

Title of Granted Patent A SECURITY SYSTEM

**** END OF REGISTER ENTRY ****